



Plate Style Magnetic Separators

Plate Magnets For Angled Chute Applications

GET A QUOTE
www.TinsleyCompany.com

TRAMP METAL

TG-01A

IMI's high intensity plate magnets feature durable welded stainless steel construction and heavy duty hinges for easy cleaning.

Flush Face (FF) Plate Magnets are designed for **above-the-flow** applications. The Flush Face model is available in Ceramic and Rare Earth designs to lift ferrous metal out of the product flow, protecting downstream processing equipment and product purity.

Exposed Pole (EP) Plate Magnets are designed for **below-the-flow** applications. The two 400 series (magnetic stainless steel) exposed poles provide added protection from wash-off without impeding the product flow. Exposed Pole models are ideal for low volume chute installations with either Ceramic or Rare Earth magnetic circuits.

Spout Style (SM) Plate Magnets feature a diverter to provide maximum tramp metal separation and superior wash-off protection for high volume **below-the-flow** applications. The diverter and 400 series (magnetic stainless steel) exposed poles provide added protection from collected metal wash-off and product degradation without impeding the product flow. Several strengths are available in Ceramic and Rare Earth designs to meet the requirements of difficult applications.

Magnet Materials for Plate Magnets:

Ceramic: Used for small to larger ferrous particle separation such as nails, bolts, washers, etc that can cause damage to processing equipment.

Rare Earth: Extremely powerful magnet is used for "fine particle" separation such as metal filings, shavings, metal wear residue, work hardened stainless steel, etc. as well as capturing larger tramp metal.

Hump Magnets (Plate-In-Chute Separators) - IMI plate magnets can be provided with engineered chutes to fit directly into your processing lines. Customer specified inlet and outlet requirements can be accommodated using custom designed housings, transitions (round or rectangular), flanges and more. Housings and chutes are available for single plate magnets, multiple plate magnets and for Manual, EZ or Self-Cleaning models.

Granulator Plate Magnet (GPM) Protect your regrind operation from tramp metal contamination with IMI's powerful Granulator Plate Magnets. These magnets are designed for easy installation in your granulator's feed tray, and are an economical way to prevent tramp metal from damaging your equipment and contaminating your product.

OPTIONS:

- Ceramic, Grade 8 Magnet Material
- Rare Earth, 52 MgOe Magnet Material
- Custom designs and mounting
- Clamping, lifting and counterweight devices
- Food Grade or Sanitary Finish
- Wear treatment
- EZ-Clean or Self-Cleaning models available
- High Temp 356°F
- Extended Length Multi-Pole for High-Speed Applications





The following items can be manufactured to conform to HACCP International's Food Safety and USDA/AMS standards:

- Pneumatic Line Magnets
- Drawer-in-Housing Magnets
- Plate Magnets
- Magnetic Tubes
- Magnetic Grates

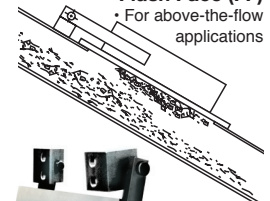

Flush Face (FF)
• For above-the-flow applications



Exposed Pole (EP)
• Typical below-the-flow exposed pole application.

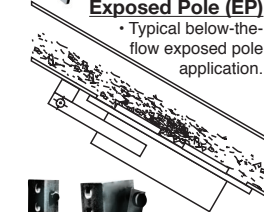

Spout Magnet (SM)
• Ideal for below-the-flow applications.

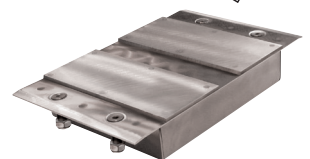
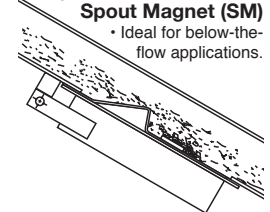

Granulator Plate Magnet (GPM)
• Ideal for Granulator Feed Trays.

Key Markets

Magnets for Unimpeded Product Flows or dry to slight moisture content; i.e. powders, granular, leafy, etc...

Related Products

Hump Magnets, Inline Separators, Extractor Magnets, Split-Flow Magnets

Plate Style Magnetic Separators

GET A QUOTE
www.TinsleyCompany.com

Drawings and Specifications For Plate Magnets

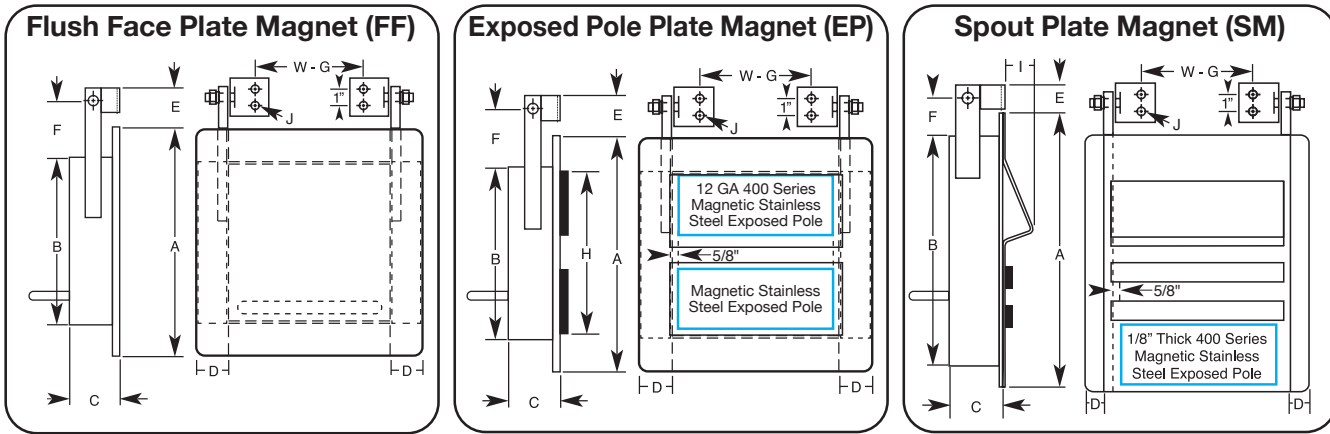

OPTIMUM CHUTE INSTALLATION

Customer installed angles on chute to match flanges

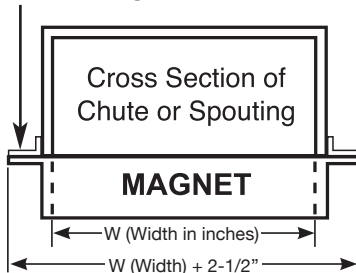

REACH-OUT		MAGNET CAPACITY	
Ceramic			
2"		Magnet Width (W) x 166.75 = CF/H	
4"		Magnet Width (W) x 333.50 = CF/H	
6"		Magnet Width (W) x 500.00 = CF/H	
8"		Magnet Width (W) x 667.00 = CF/H	
Rare Earth			
3"		Magnet Width (W) x 250.12 = CF/H	
5"		Magnet Width (W) x 416.87 = CF/H	

CF/H x 0.02832 = Capacity in Cubic Meters Per Hour

Ceramic Plate Magnet Dimensions

Flush Face	Exposed Pole	Spout Magnet	Reach-Out (In.)	Dimensions (Inches)								EP Only	SM Only	Approx. Wt. Per Inch of Width (W)
				A	B	C	D	E	F	G	H			
FF	EP	SM	2	9.38	7.38	1.45	1.0	1.19	1.81	0.90	5.63	0.61	0.25	2.38 Lbs./In.
FF	EP	SM	4	13.13	11.13	2.70	1.0	2.75	2.75	2.25	4.56	1.25	0.5	7.20 Lbs./In.
FF	EP	SM	6	17.13	15.13	4.20	1.0	2.75	2.75	2.25	13.38	1.25	0.5	13.06 Lbs./In.
FF	EP	SM	8	22.38	20.38	8.38	1.0	2.75	2.75	2.25	18.63	1.25	0.5	32.33 Lbs./In.

Rare Earth Plate Magnet Dimensions

Flush Face	Exposed Pole	Spout Magnet	Reach-Out (In.)	Dimensions (Inches)								EP Only	SM Only	Approx. Wt. Per Inch of Width (W)
				A	B	C	D	E	F	G	H			
FF	EP	SM	3	8.00	6.00	1.28	1.0	1.19	1.81	0.90	4.25	0.68	0.25	2.04 Lbs./In.
FF	EP	SM	5	11.38	9.38	2.28	1.0	2.75	2.75	2.25	7.63	1.25	0.5	5.59 Lbs./In.

Notes:

- All EZ and SC Plate Magnets have lift lugs on the back of the magnet for handling.
- Magnets with 2" & 3" Reach-Out have hinges with a single hole.

*Maximum operating temperature 180°F

Plate Magnet Ordering Guide Example: EPC06-12

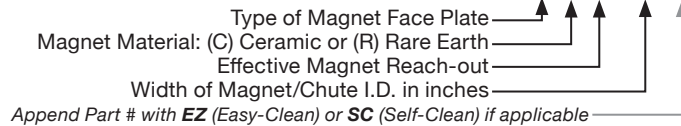

Granulator Plate Magnets (Ceramic Magnet Material Only)

FEATURES:

- Protect your regrind operation from damaging tramp metal
- Designed for installation in the granulator's feed tray
- Low profile design for smooth flow over the magnet face
- Mounts with provided 4-20 stainless steel bolts and lock nuts
- Stainless steel housing with 400 series stainless steel magnetic poles

INSTALLATION:

- Cut an opening in your feed tray
- Set the magnet in the opening in the feed tray and mark the location of the mounting holes
- Remove the magnet and drill the four mounting holes into the feed tray
- Set the magnet into the opening, insert the bolts into the mounting holes, thread & tighten the nuts onto the bolts

Model No.	Overall Width (A)	Magnet Width (B)	Magnet Length (C)
GPM0550	5.50"	5.10"	6.25"
GPM0750	7.50"	7.10"	6.25"
GPM0950	9.50"	9.2"	6.25"
GPM1150	11.50"	11.10"	6.25"
GPM1300	13.00"	12.60"	6.25"
GPM1500	15.00"	14.60"	6.25"
GPM1700	17.00"	16.60"	6.25"
GPM1900	19.00"	18.60"	6.25"
GPM2100	21.00"	20.60"	6.25"
GPM2300	23.00"	22.60"	6.25"

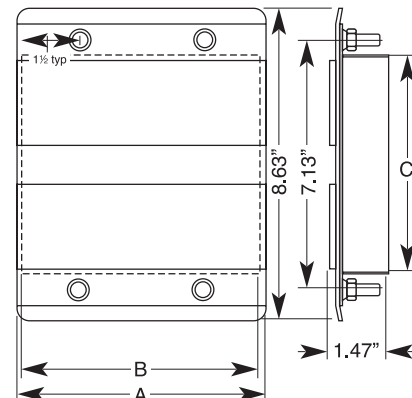

Plate Style Circuits - For Chute Applications

Hump Magnets (Plate-In-Chute Separators) - IMI plate magnets can be provided with engineered chutes to fit directly into your processing lines. Customer specified inlet and outlet requirements can be accommodated using custom designed housings, transitions (round or rectangular), flanges and more. Housings and chutes are available for single plate magnets, multiple plate magnets and for Manual, EZ or Self-Cleaning models.

EZ-Clean and Self Cleaning Spout Magnets are designed to simplify the cleaning process and to increase processing line efficiency. These cleaning options feature spout faced stripper pans that swing out of the product flow and away from the magnet to release collected metal. The EZ-Clean unit is operated manually by unclamping the magnet and pulling the assembly into the open position. The Self-Cleaning model operates on the same principle but uses either pneumatic cylinders or electric actuators to open and close the plate magnet at user specified intervals. Standard units are designed for 45° to 60° chutes. Custom units available for other chute angles upon request.

FEATURES:

- All stainless steel construction
- Ceramic or Rare Earth Magnets
- Customary finish
- DE-STA-CO clamps for a positive seal
- Leak resistant seals

OPTIONS:

- Mild steel construction
- Food Grade Finish
- Pre-drilled Flanges
- Round inlet and outlet transitions
- Rectangular or square transitions
- EZ-Clean stripper design (recommended for all models)
- Self-Cleaning design
- Collection pans
- Metal guarding (Self-Cleaning)
- Wear Resistant Linings
- High Temp

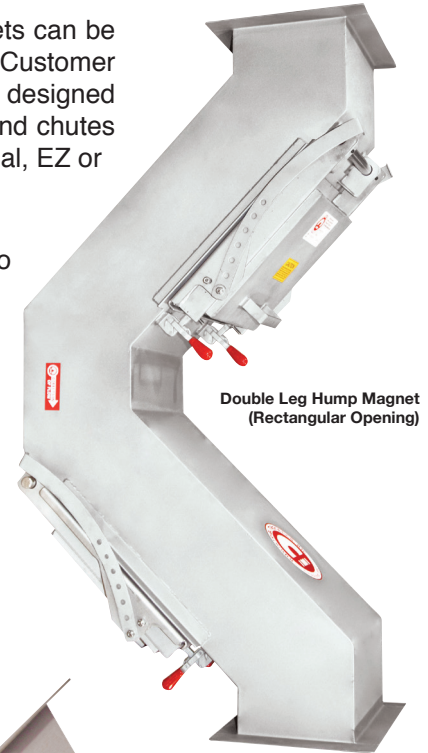

Double Leg Hump Magnet
(Rectangular Opening)



Single Leg Hump Magnet
(Electric Actuated)



Single Leg Hump Magnet (Air Actuated)

Hump Magnets (Plate-in-chute separators)

GET A QUOTE
www.TinsleyCompany.com

Plate Style Circuits - For Chute Applications

DOUBLE LEG - RECTANGULAR OPENINGS (Using IMI 6" Reach-out Magnets)

Circuit	Model Number	A (I.D.)	B (I.D.)	C Width	D Height	Ft ³ /Hr.	Approx. Weight Lbs.
R05	H07X10R05	7	10	22.875	42	4,167	162
R05	H07X12R05	7	12	22.875	42	5,000	194
R05	H07X14R05	7	14	22.875	42	5,833	227
R05	H07X20R05	7	20	22.875	42	8,333	324
R05	H07X26R05	7	26	22.875	42	10,833	421
R05	H07X34R05	7	34	22.875	42	14,167	550
R05	H07X40R05	7	40	22.875	42	16,667	647
C06	H08X10C06	8	10	23.875	44	5,000	311
C06	H08X12C06	8	12	23.875	44	6,000	374
C06	H08X14C06	8	14	23.875	44	7,000	436
C06	H08X20C06	8	20	23.875	44	10,000	623
C06	H08X26C06	8	26	23.875	44	13,000	809
C06	H08X34C06	8	34	23.875	44	17,000	1058
C06	H08X40C06	8	40	23.875	44	20,000	1245

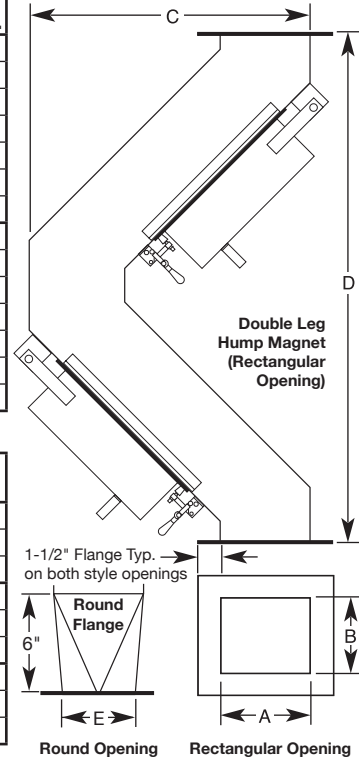

DOUBLE LEG - ROUND OPENINGS (Using IMI 6" Reach-out Magnets)

Circuit	Model Number	E Inlet Dia.	C Width	D Height	Ft ³ /Hr.	Approx. Weight Lbs.
C06	H06DC06	6	19-1/2	57	1,875	142
C06	H08DC06	8	21-1/2	57	3,281	174
C06	H09DC06	9	21-1/2	57	3,938	210
C06	H10DC06	10	21-1/2	57	4,594	245
C06	H12DC06	12	21-1/2	57	6,563	348
C06	H14DC06	14	21-1/2	57	8,531	452
C06	H16DC06	16	22-1/2	60	9,188	486
C06	H18DC06	18	23	60	12,750	589
C06	H20DC06	20	23	60	15,000	692

NOTE: All Dimensions Are Stated In Inches. Ft³/Hr. based on 200 FPM at 75% full.

All standard models are available with EZ-Clean (E) and Self-Clean (S) options. Append the letter **E** (for EZ-Clean) or **S** (for Self-Clean) to the end of the part numbers listed in the tables above to order EZ-Clean or Self-Clean options.

Single Leg Hump Magnets

Our Single Leg Hump Magnet is designed to be placed in product flows at angles 45° or less from horizontal. If angle of flow is greater than 45°, please contact IMI for the proper magnet.

SINGLE LEG - RECTANGULAR OPENINGS (Using IMI 6" Reach-out Magnets)

Circuit	Model Number	A (I.D.)	B (I.D.)	C Offset	D Height	Ft ³ /Hr.	Approx. Weight Lbs.
R05	HH07X8R05	7	8	22.875	21	3,333	65
R05	HH07X12R05	7	12	22.875	21	5,000	97
R05	HH07X13R05	7	13	22.875	21	5,417	105
R05	HH07X14R05	7	14	22.875	21	5,833	113
R05	HH07X18R05	7	18	22.875	21	7,500	146
R05	HH07X60R05	7	60	22.875	21	25,000	485
C06	HH08X8C06	8	8	23.875	22	4,000	125
C06	HH08X12C06	8	12	23.875	22	6,000	187
C06	HH08X13C06	8	13	23.875	22	6,500	202
C06	HH08X14C06	8	14	23.875	22	7,000	218
C06	HH08X18C06	8	18	23.875	22	9,000	280
C06	HH08X60C06	8	60	23.875	22	30,000	934

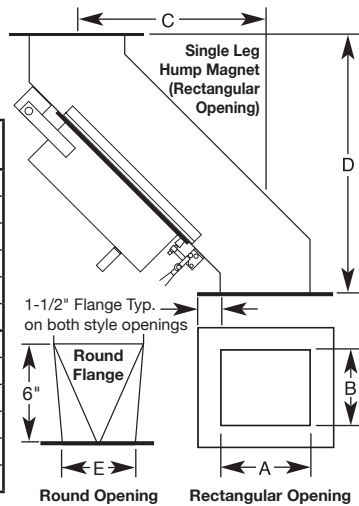

SINGLE LEG - ROUND OPENINGS (Using IMI 6" Reach-out Magnets)

Circuit	Model Number	E Inlet Dia.	C Offset	D Height	Ft ³ /Hr.	Approx. Weight Lbs.
C06	HH06DC06	6	14-1/2	35	1,875	71
C06	HH08DC06	8	14-1/2	35	3,281	87
C06	HH09DC06	9	14-1/2	35	3,938	105
C06	HH10DC06	10	14-1/2	35	4,594	123
C06	HH12DC06	12	14-1/2	35	6,563	174
C06	HH14DC06	14	14-1/2	35	8,531	226
C06	HH16DC06	16	14-1/2	37	9,188	295
C06	HH18DC06	18	14-1/2	37	12,750	295
C06	HH20DC06	20	14-1/2	37	15,000	346

NOTE: All Dimensions Are Stated In Inches. Ft³/Hr. based on 200 FPM at Max Reach Out.

All standard models are available with EZ-Clean (E) and Self-Clean (S) options. Append the letter **E** (for EZ-Clean) or **S** (for Self-Clean) to the end of the part numbers listed in the tables above to order EZ-Clean or

NEED A QUOTE?

Please fill out the TG-01Q questionnaire as completely as possible to ensure the proper magnet selection for your application.