



The Ox[®] Drawer-In-Housing

Heavy Duty EZ-Clean & Self-Cleaning Housing

GET A QUOTE
www.TinsleyCompany.com

TRAMP METAL

TG-03C

APPLICATION:

- Capture and remove fine ferrous tramp metal particles from vertical product flow.
- Coated tubes and special wiper seals virtually eliminate sticking, galling, static buildup and corrosion on the tubes.

INTRODUCTION:

IMI's Ox[®] Heavy Duty Drawer-In-Housing incorporates design elements that are essential for optimum magnetic separation performance in a variety of processing conditions. Those include external elements like: ambient temperature and humidity as well as material contents which cause challenges such as bridging, abrasion, corrosion and galling.

The main body of the housing consists of 2 to 3 rows of Nedox[®] coated round magnetic tubes that are assembled into drawers. Each row of magnetic tubes is aligned on alternating centers from the row directly above or below it.

As product flows into the top of the housing, it's forced to cascade in a zig-zag pattern from row to row over the magnetic tubes. This cascading effect ensures maximum tramp metal capture since the product comes in direct and repeated contact with a magnet as it travels through the housing.

As ferrous metal passes through the magnetic field, it is held to the tubes and separated from the product. The metal must be cleaned from the tubes on a regular basis to prevent buildup and subsequent wash-off back into the product flow.

OPERATION:

The Nedox[®] coating on the tubes prevents sticking problems associated with certain products and processing conditions. This allows the cleaning operation to function easier than if the tubes were caked with sticky or moist products. The heavy duty Hydex[®] wiper seals ensure that all collected metal and product residue is wiped free of the tubes without damaging the seals. The cleaning process for the Ox[®] can be automated with IMI's proven Self-Cleaning design or it can be accomplished manually with the EZ-Clean design (see reverse side for details).

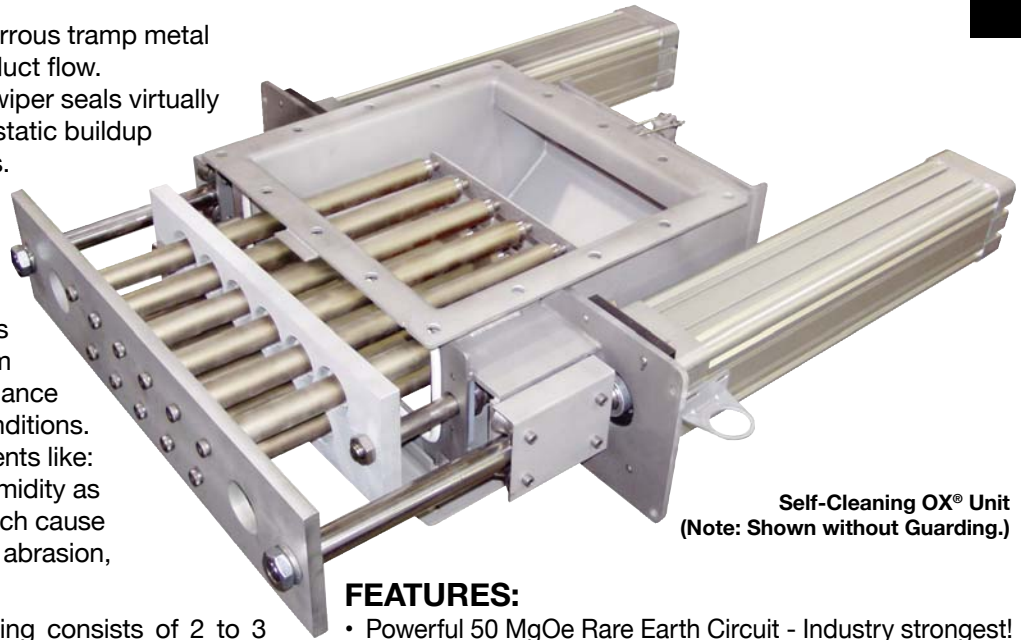

Self-Cleaning Ox[®] Unit
(Note: Shown without Guarding.)

FEATURES:

- Powerful 50 MgOe Rare Earth Circuit - Industry strongest!
- Hydex[®] Wiper Seals - Ideal for removing sticky residue
- Nedox[®] Coated Tubes - Provides protection from abrasive materials and are self-lubricating to help prevent build-up and galling
- Compression Spring Assisted Seal Plate
- Stainless Steel Construction
- Food Grade Silicone Gasket Material - leak resistant operation
- Collection Pan for Captured Metal
- Drawer and/or Guard Lock-Out
- Hinged Rear Access Door with Lock-Out
- Tool Free Guard Removal
- All cylinders include magnetic pistons

OPTIONS:

- Custom Sizes and Transitions Available
- Housing finish and welding surface treatments
- Alternate Tube spacing for special applications
- Alternate Gasket Material Available
- Nema #9 solenoids (Self-Cleaning)
- Other Stainless Steel Grades available
- Individual cleaning drawers
- MAGnanoSHIELD[®] Coated Tubes - FDA compliant, antimicrobial coating that offers 99.9999% microbe resistance to assorted bacteria and fungus strains

Pictured:
Examples of the
Drawer and the Rear
Access Door Lock-Out



Key Markets

Mid-stream magnets for dry, free flow powders to granular products; i.e. food, feed, grain, plastics, chemical

Related Products

Magnetic Drawer-In-Housings, Magnetic Tubes & Grates, Large Tube Housing, Pipe Magnets

All Photos And Drawings Represent The Products At The Time Of Publication (03/14)

Standard Sizes & Specifications

OX[®] Specifications (EZ & Self-Cleaning):

- 50 MgOe Rare Earth Magnetic Circuit
- Nedox[®] Coated Tubes Protects Against Wear, Sticking & Galling
- Hydrex[®] Heavy Duty Wear Resistant Wiper Seals
- Heavy Duty Compression Springs to Ensure Proper Seal Plate Positioning During Cleaning Operation
- Food Grade Silicone Gasket Material
- Welded Stainless Steel Housing
- Rear Access Door for Cleaning or Maintenance Conditions
- De-Sta-Co Clamps for Easy Opening & Secure Seal
- Removable Catch Pan

OX[®] EZ-CLEAN (EZ) DRAWER-IN-HOUSING DIMENSIONS:

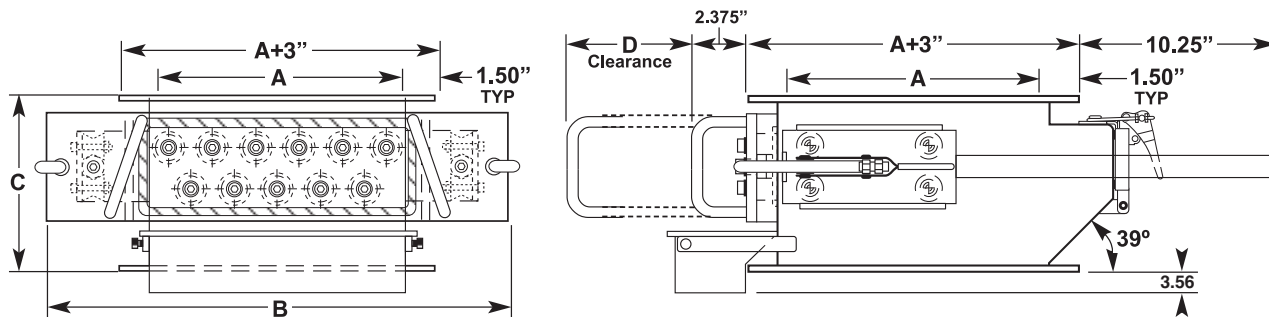

EZ-Clean Ox	A	B	C	D	No. of Tubes	No. of Banks	No. of Drawers	Ft. ³ /Hr.	Bulk Density (Lb./Hr.)				Approx. Wt. (Lbs.)
									40 Lb./Ft ³ .	50 Lb./Ft ³ .	60 Lb./Ft ³ .	70 Lb./Ft ³ .	
OXH0808R2EZ	8	18	8	13	7	2	1	800	32,000	40,000	48,000	56,000	114
OXH1010R2EZ	10	20	8	15	9	2	1	1,250	50,000	62,500	75,000	87,500	135
OXH1212R2EZ	12	22	8	17	11	2	1	1,800	72,000	90,000	108,000	126,000	157
OXH1414R2EZ	14	24	8	19	13	2	1	2,450	98,000	122,500	147,000	171,500	182
OXH1616R2EZ	16	26	8	21	15	2	1	3,200	128,000	160,000	192,000	224,000	209
OXH1818R2EZ	18	28	8	23	17	2	1	4,050	162,000	202,500	243,500	283,500	237

Note: All dimensions are stated in inches.

OX[®] SELF-CLEANING (SC) DRAWER-IN-HOUSING DIMENSIONS:

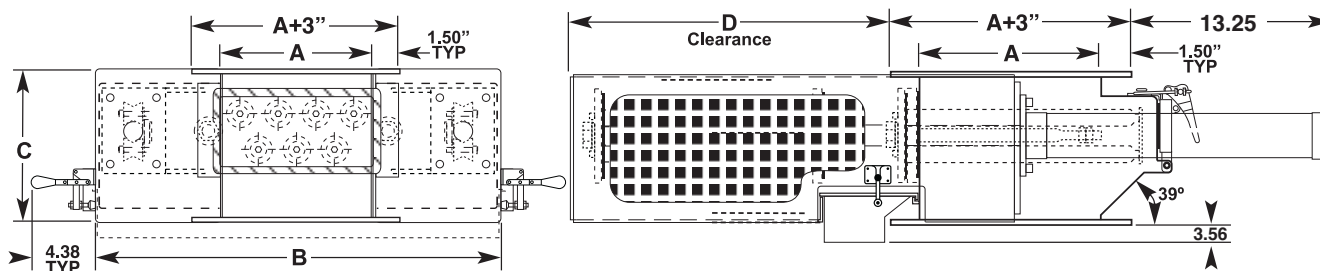

Self-Clean Ox	A	B	C	D	No. of Tubes	No. of Banks	No. of Drawers	Ft. ³ /Hr.	Bulk Density (lbs./ft. ³)				Approx. Wt. (Lbs.)
									40 Lb./Hr.	50 Lb./Hr.	60 Lb./Hr.	70 Lb./Hr.	
OXH0808R2SC	8	21 ⁷ / ₈	8	14	7	2	1	800	32,000	40,000	48,000	56,000	127
OXH1010R2SC	10	23 ⁷ / ₈	8	16	9	2	1	1,250	50,000	62,500	75,000	87,500	151
OXH1212R2SC	12	25 ⁷ / ₈	8	18	11	2	1	1,800	72,000	90,000	108,000	126,000	175
OXH1414R2SC	14	27 ⁷ / ₈	8	20	13	2	1	2,450	98,000	122,500	147,000	171,500	206
OXH1616R2SC	16	29 ⁷ / ₈	8	22	15	2	1	3,200	128,000	160,000	192,000	224,000	236
OXH1818R2SC	18	31 ⁷ / ₈	8	24	17	2	1	4,050	162,000	202,500	243,500	283,500	263
OXH2020R2SC	20	33 ⁷ / ₈	8	26	19	2	1	5,000	200,000	250,000	300,000	350,000	300
OXH2222R2SC	22	35 ⁷ / ₈	8	28	21	2	1	6,050	242,000	302,500	363,000	423,500	346
OXH2424R2SC	24	37 ⁷ / ₈	8	30	23	2	1	7,200	288,000	364,000	432,000	504,000	388

Note: All dimensions are stated in inches.

Capacities listed above are based on properly fed dry (free flowing) bulk materials. Some materials may have higher or lower capacities.