



LTH™ Drawer-In-Housing

GET A QUOTE
www.TinsleyCompany.com

Optimum Separation for Difficult Flowing Products

TRAMP METAL

TG-03D

APPLICATION:

- Capture and remove ferrous tramp metal particles from vertical product flows
- Ideal for flour, powdered sugar and products with a tendency to bridge
- Large 3" tubes with steep in-line diverters prevent bridging and clogging of fine or moist products

INTRODUCTION:

IMI's LTH™ (Large Tube Housing) incorporates 3 inch diameter Rare Earth tubes on 6 inch centers into our proven Drawer-In-Housing configuration for optimum ferrous metal separation for difficult flowing products. These larger tubes are placed in the housing directly below steep angled diverters that prevent product from bridging or building up on the tubes. The spacing between the tubes is much larger than in a traditional housing with 1 inch diameter tubes, allowing for product to flow freely through the housing. The 52MgOe magnetic circuit achieves 28 lbs. of pull value on a 1/2" ball - the highest value of any 3" circuit available on the market. Combined with a gauss averaging 12,385, our design offers the strongest and most effective solution to capture ferrous pieces, as well as smaller fines and weakly magnetic contaminants from a product flow.

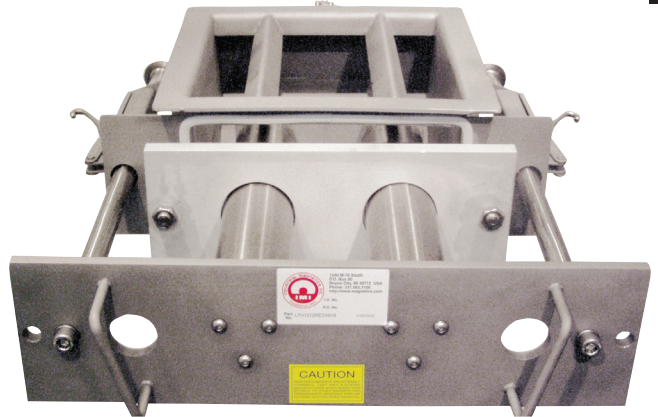

As product flows into the top of the housing, it's forced past the tubes by the diverters. This ensures that the product comes in direct contact with a magnet as it travels through the housing.

As ferrous metal passes through the magnetic field, it is held to the tubes and separated from the product. The metal must be cleaned from the tubes on a regular basis to prevent buildup and subsequent wash-off into the product flow.

FEATURES:

- Powerful 52 MgOe Rare Earth Circuit - Designed for optimum reach-out and surface holding strength
- BUNA Wiper Seals - for removing collected metal
- Compression Spring Assisted Seal Plate
- Stainless Steel Construction
- Food Grade Silicone Gasket Material - for leak resistant operation
- Drawer and/or Guard Lock-Out
- Hinged Rear Access Door with Lock-Out
- Collection Pan for Captured Metal
- Tool Free Guard Removal
- All cylinders include magnetic pistons

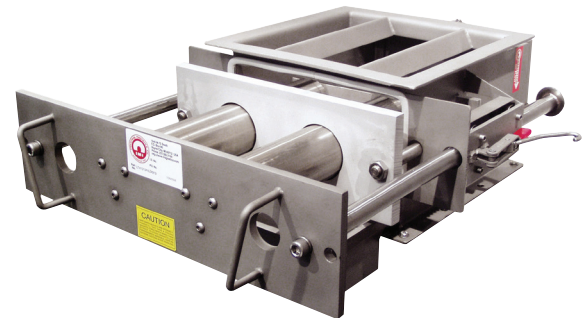

OPTIONS:

- Custom sizes and transitions available
- Housing finish and welding surface treatments
- Two drawer design with 3 or 5 vertically offset tubes
- Nema #9 solenoids (self-cleaning only)
- Other Stainless Steel Grades available
- Hydex® Wiperseals
- Nedox® Coated Tubes - Provides protection from abrasive materials and is self-lubricating to help prevent build-up and galling
- MAGnanoSHIELD® Coated Tubes - FDA compliant, antimicrobial coating that offers 99.9999% microbe resistance to assorted bacteria and fungus strains

Pictured:
Examples of the
Drawer and the Rear
Access Door Lock-Out

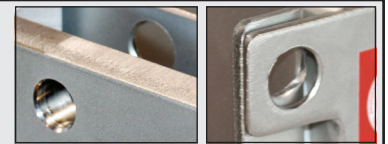

Key Markets

Food & Grain, Bulk Powder

Related Products

Magnetic Drawer-In-Housings, Extractor/Split-Flow Magnets, Magnetic Tubes & Grates, The Ox, Pipe Magnets

All Photos And Drawings Represent The Products At The Time Of Publication (07/19)

Drawings and Standard Model Information for Large Tube Housing™

EZ-CLEAN (EZ) DRAWER-IN-HOUSING DIMENSIONS:

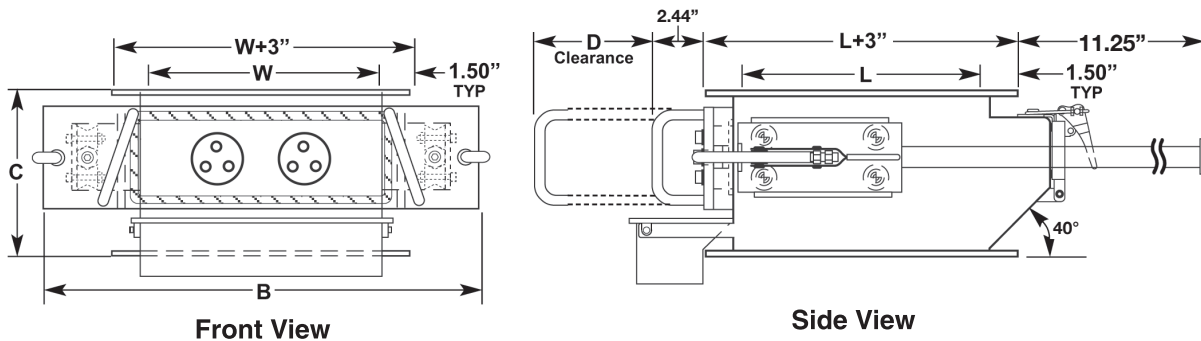

SELF-CLEANING (SC) DRAWER-IN-HOUSING DIMENSIONS:

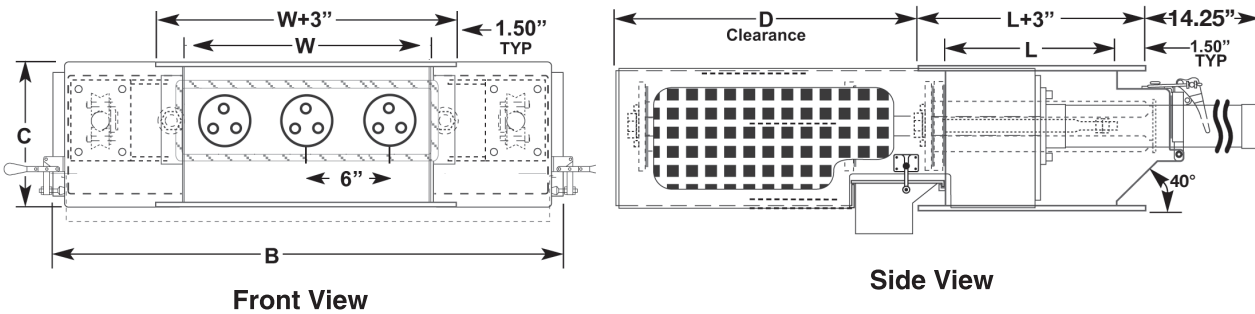

Standard Part No.	Inlet I.D. (L x W)	Width(EZ) B	Width(SC) B	Height(EZ/SC) C	Clearance (EZ) D	Clearance (SC) D	# Of Tubes	Weight(EZ) Lbs.	Weight(SC) Lbs.
LTH1212R1(EZ/SC)	12 x 12	22	24	10	18	19	2	140	225
LTH1414R1(EZ/SC)	14 x 14	24	26	10	20	21	2	160	235
LTH1616R1(EZ/SC)	16 x 16	26	28	10	22	23	2	200	255
LTH1818R1(EZ/SC)	18 x 18	28	30	10	24	25	3	220	280

Note: All dimensions are stated in inches

Drawer-In-Housing Ordering Guide: LTH

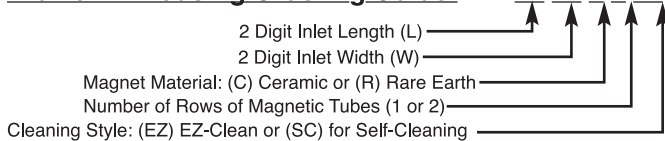

Example: LTH1812R1EZ = 18"x 12" Inlet, Rare Earth, 1 Row, EZ-Clean