

Swinglink® Heavy Duty Bucket Elevators

Industrial Applications

- Soap/Detergents
- Ceramics
- Ammunition
- Fiberglass
- Talc powder
- Aluminum scrap
- Salt
- Rocks/minerals
- Batteries
- Carbon Black
- Catalysts
- Chemicals
- Fertilizer
- Glass Cullet
- Metal Powders

Features & Benefits:

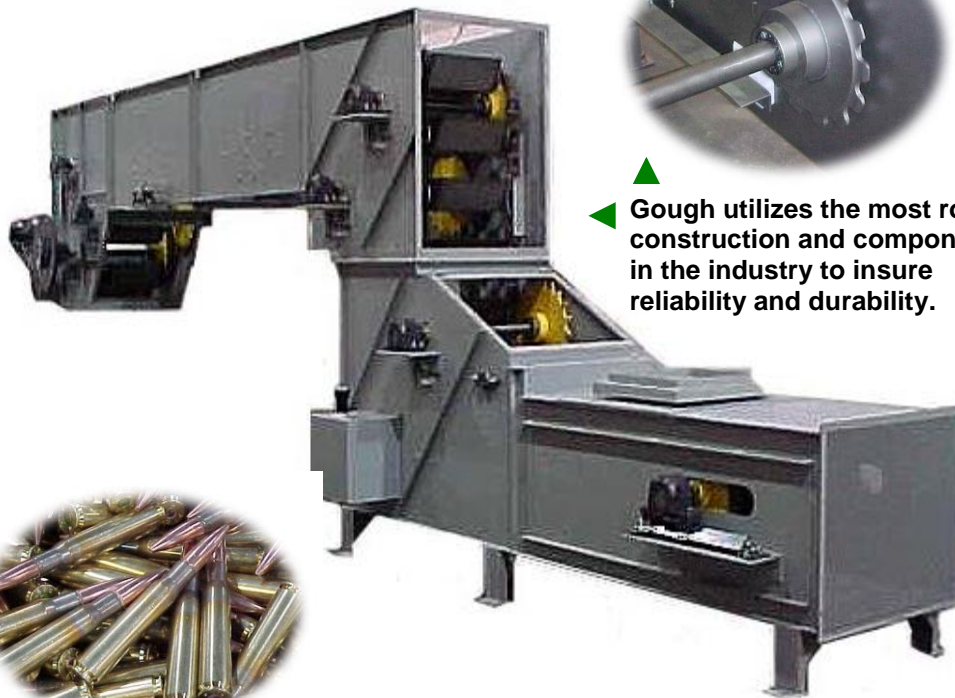

▲ Gough utilizes the most robust construction and components in the industry to insure reliability and durability.



▲ Heavy-duty buckets in stainless steel, carbon steel and plastic are available.

▼ Gough bucket conveyors utilize the strongest chain in the industry.

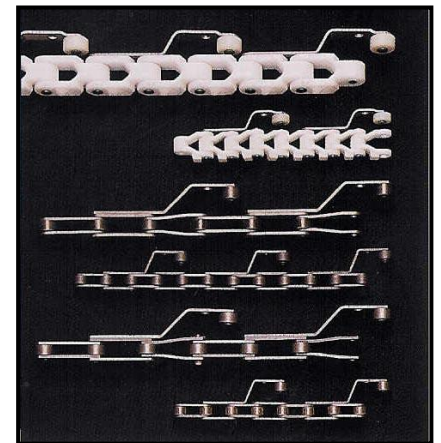

▲ Gough elevators are designed to handle heavy duty products such as ammunition.



Tough, Gentle, Clean

Gough Econ, Inc.

P.O. Box 668583, Charlotte, NC 28266-8583

Phone: 800.264-6844 Fax: 704.392.8706

E-Mail: sales@goughecon.com

Website: www.goughecon.com

Form: swinglink®ind.doc

Rev 2

Swinglink® Heavy Duty Bucket Elevators

Typical Circuit Configurations

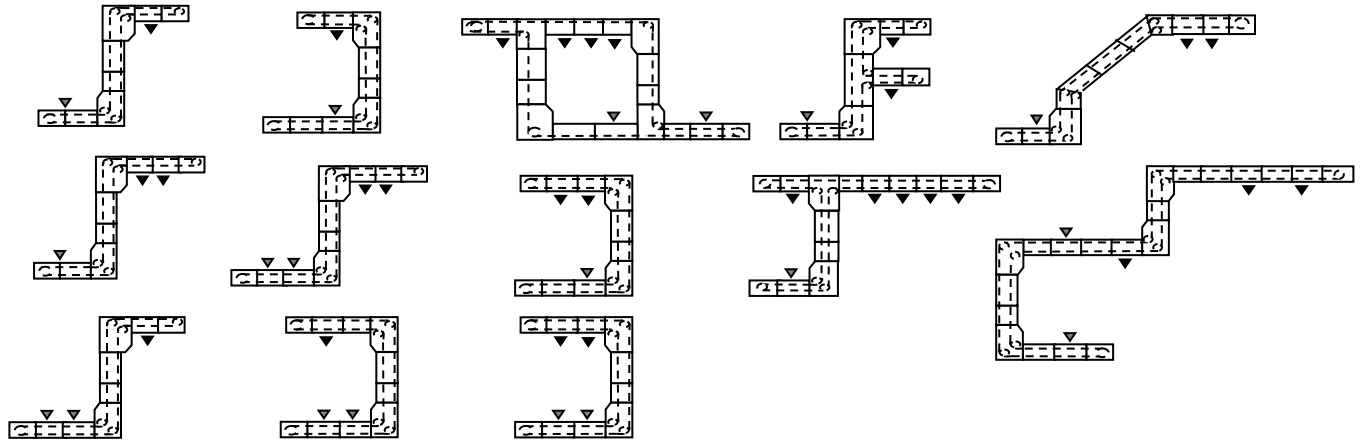

Typical Capacity Chart (in CFH)

Speed (FPM)	S-SERIES		BUCKET SIZE					L-SERIES	
	9" Wide	18" Wide	M-SERIES					36" Wide	48" Wide
			9" Wide	12" Wide	18" Wide	24" Wide	36" Wide		
20	75	145	122	173	267	350	492	801	1047
22	82	160	134	190	294	385	542	881	1152
24	90	175	146	207	320	420	591	962	1256
26	97	189	158	225	347	456	640	1042	1361
28	105	204	171	242	374	491	689	1122	1466
30	112	218	183	259	400	526	739	1202	1570
32	120	233	195	276	427	561	788	1282	1675
34	127	247	207	294	454	596	837	1362	1780
36	135	262	219	311	480	631	886	1442	1884
38	142	276	232	328	507	666	936	1523	1989
40	150	291	244	346	534	701	985	1603	2094
42	157	305	256	363	560	736	1034	1683	2198
44	165	320	268	380	587	771	1083	1763	2303
46	172	335	280	397	614	806	1133	1843	2408
48	180	349	293	415	641	841	1182	1923	2513
50	187	364	305	432	667	876	1231	2003	2617
52	195	378	317	449	694	911	1280	2084	2722
54	202	393	329	467	721	946	1330	2164	2827
56	210	407	341	484	747	981	1379	2244	2931
58	217	422	354	501	774	1016	1428	2324	3036
60	225	436	366	518	801	1051	1477	2404	3141

1. Based on 60% fill.

Tough, Gentle, Clean

Gough Econ, Inc.

P.O. Box 668583, Charlotte, NC 28266-8583

Phone: 800.264-6844 Fax: 704.392.8706

E-Mail: sales@goughecon.com

Website: www.goughecon.com

Form: swinglink®ind.doc

Rev 2



Swinglink® Heavy Duty Bucket Elevators

Typical Engineering Data

Construction:

Open folded construction or totally enclosed designs available in carbon or stainless steel. Custom engineered such as Z-purge and dust tight are available.

Materials of Construction: 11 gauge folded steel side panels, with 14 gauge steel, Lexan stainless steel cover panels available.

All elevators are covered up to 7' for safety purposes.

Bucket Design:

Sizes: "S" Series: 6", 9", 12", 18" wide
"M" Series: 9", 12", 18", 24", 30", 36" wide
"L" Series: 18", 24", 30", 36", 42", 48" wide

Pitch: "S" Series: 6" centers
"M" Series: 9" centers
"L" Series: 12" centers

Materials of Construction: Carbon steel, stainless steel or polycarbonate as required. (Note: 6" bucket for S Series is not available in plastic.)
Bucket pins: Stainless steel type 303.

Tipping mechanism: Individually replaceable "teardrop" and/or "t" cam. 360° rotations.

Chain Design:

"S" Series: C.S. – 1.5" pitch
S.S – 1.5" pitch

"M" Series: C.S. – 3" pitch
S.S – 3" pitch
Plastic – 3" pitch

"L" Series: C.S. – 3" pitch
S.S – 3" pitch
Plastic – 3" pitch

Materials of Construction: Acetal plastic, carbon steel or stainless steel available.

Tensile strengths – 1,500 lbs – 24,000 lbs
Working loads – 300 - 4,800 lbs

Sprocket & Shaft Design:

Easy removable sprockets made from either steel (for steel chains) or a polymeric compound (for plastic chains).

Sprocket/shaft bearing:

Sealed flange bearing

Lubrication:

Lubrication required on CS & SS chains. (Lubrication used depends on application)
No lubrication required on plastic chain.

Temperature:

-22 °F (-30 °C) up to 230 °F (110 °C)
(120 °F highest recommended temperature for plastic buckets.)
(Higher temperature buckets available)

Finish:

Steel-It™ air dry polyurethane. Epoxy coating is available.

In Feed Options:

Controlled in feed recommended.
Multiple in feed option available.

Discharge Options:

"Over the end" discharge.
Single or multiple discharge(s) anywhere in circuit available.

Drives:

Drive HP, voltage, etc dependent upon application. Motor drives into a gearbox, which is then transferred, via transmission chain and sprockets. A torque limiter provides protection to elevator main chains and components.

Tough, Gentle, Clean

Gough Econ, Inc.

P.O. Box 668583, Charlotte, NC 28266-8583

Phone: 800.264-6844 Fax: 704.392.8706

E-Mail: sales@goughecon.com

Website: www.goughecon.com

Form: swinglink®ind.doc

Rev 2

Typical Operating Description

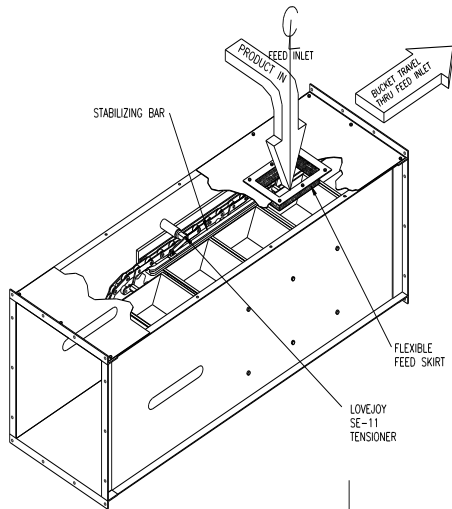

Standard design provides for in feed on top "row" of buckets; however, other in feed designs are available.

Multiple in feed options are available.

Over the end discharge is available

Single or **multiple discharges** anywhere in circuit are available. Discharge is on lower run.

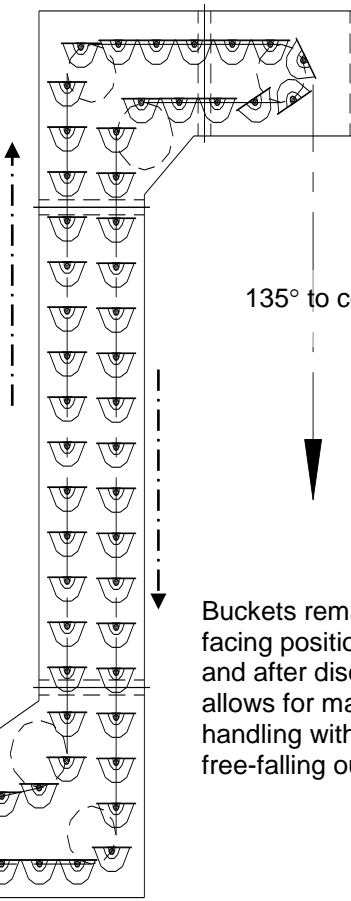

135° to complete 360° rotation as required.

Buckets remain in upward facing position while loaded and after discharge. This allows for maximum gentle handling without product free-falling out of buckets.

Buckets overlap when in the horizontal position to insure that there is no product spillage during loading of product into buckets.

Tough, Gentle, Clean

Gough Econ, Inc.

P.O. Box 668583, Charlotte, NC 28266-8583

Phone: 800.264-6844 Fax: 704.392.8706

E-Mail: sales@goughecon.com

Website: www.goughecon.com

Form: swinglink®ind.doc

Rev 2